

TECHNICAL DETAILS//MS 943

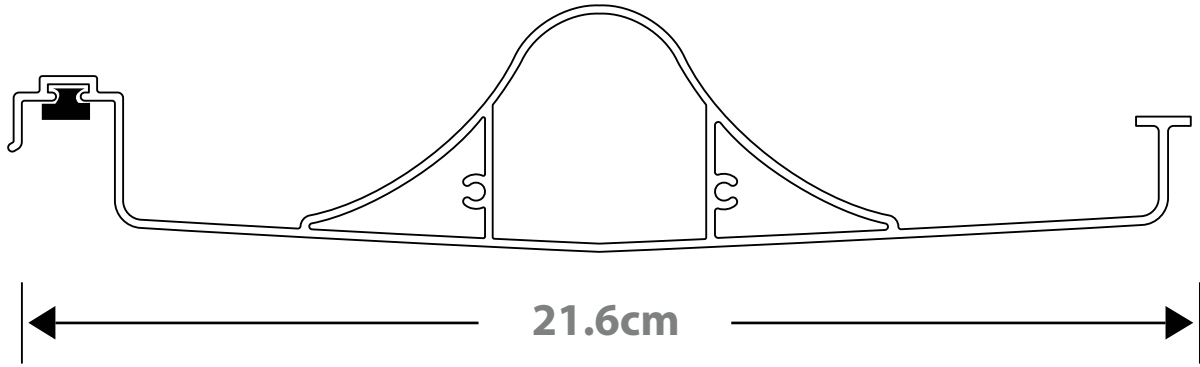

BLADE SPECIFICATIONS

// Blade cover - opening system	200 mm	// Weight per lineal metre	1.996 kgm
// Weight per square metre - opening system	9.98 kg/sqm	// Actual blade width	216 mm
// Blade centres - opening system	200 mm		

INSTALLATION OPTIONS

OPENING DIRECTION OF BLADES

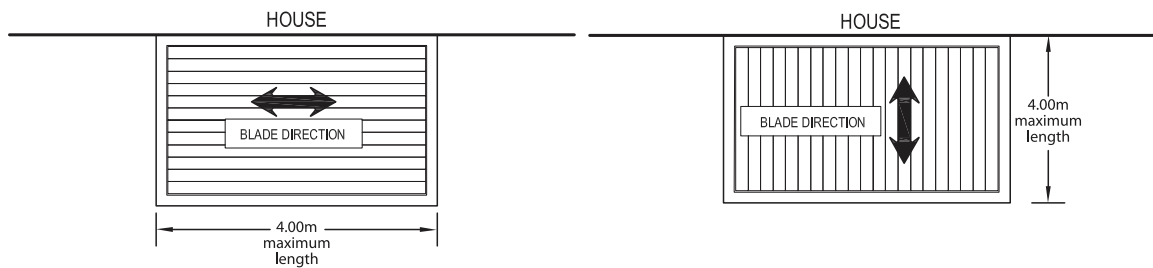

By placing the blades parallel to the wall, there are no limitations regarding the **length** and **width** of the structure

By placing the blades vertical to the wall, there are no limitations regarding the **width** of the structure

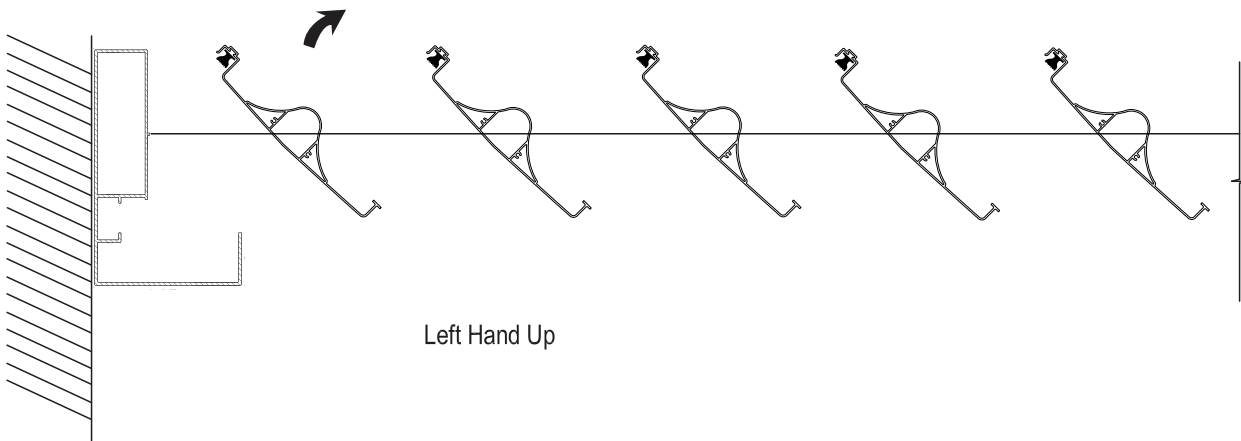

MAMAS STAVROU LTD
Aluminium Pergolas
Sun-breakers & Louvers

Τηλ.: 22 429151, 22 420069. Φαξ: 22 316609

www.mamastavrou.com

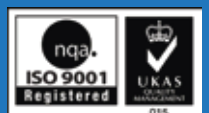

TECHNICAL DETAILS//MS 943

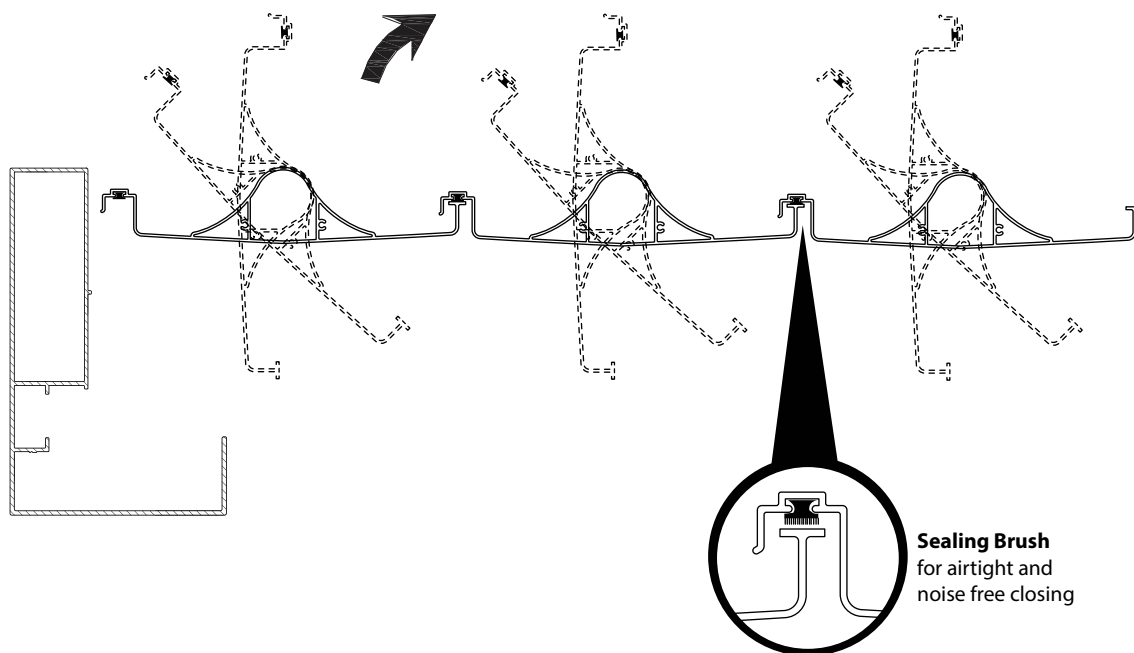
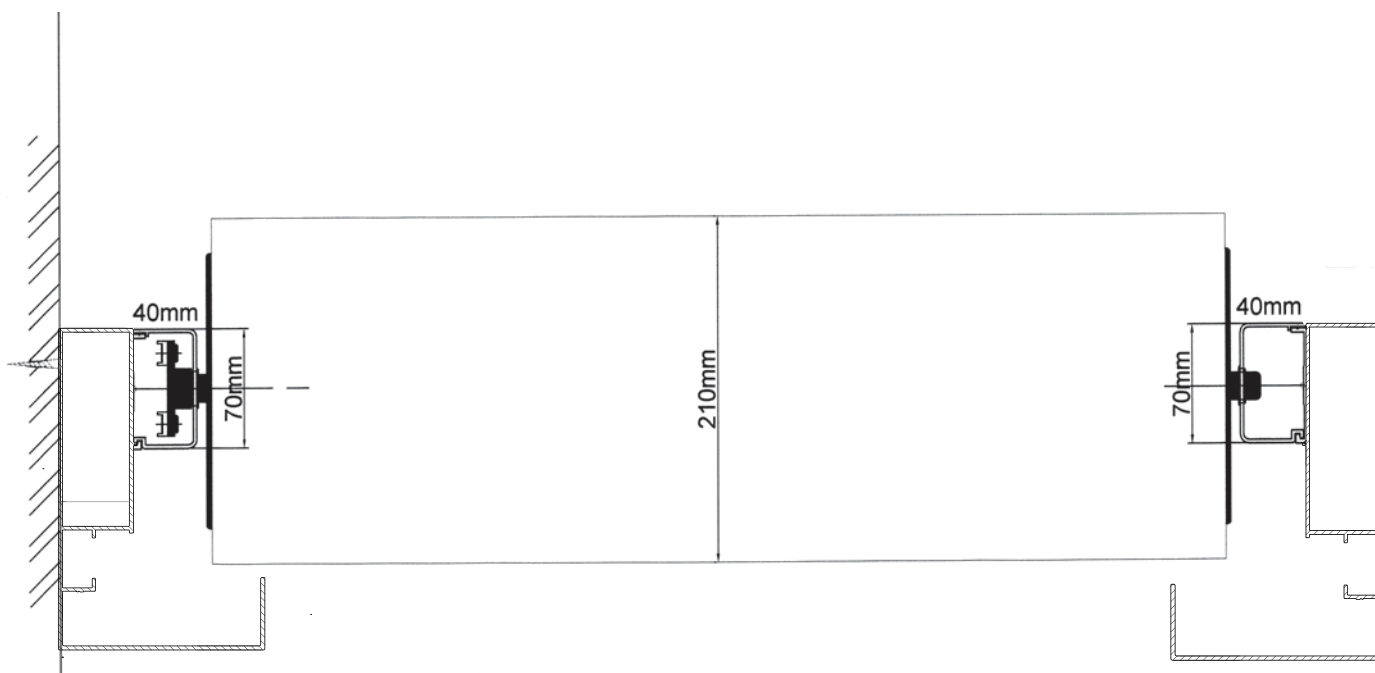

MAMAS STAVROU LTD
Aluminium Pergolas
Sun-breakers & Louvers
Τηλ.: 22 429151, 22 420069. Φαξ: 22 316609

www.mamastavrou.com



Remote control operation

IMPORTANT PLEASE NOTE: We recommend that at an early stage involve your electrician. This applies for both new and existing buildings. Determine with us how to achieve the outcomes you would like against possible limitations caused by the building. Mamas Stavrou Ltd will provide a wiring diagram and installation instructions.

The remote control unit controls up to 5 linear actuators simultaneously or individually. Maximum construction size per linear actuator 20m².

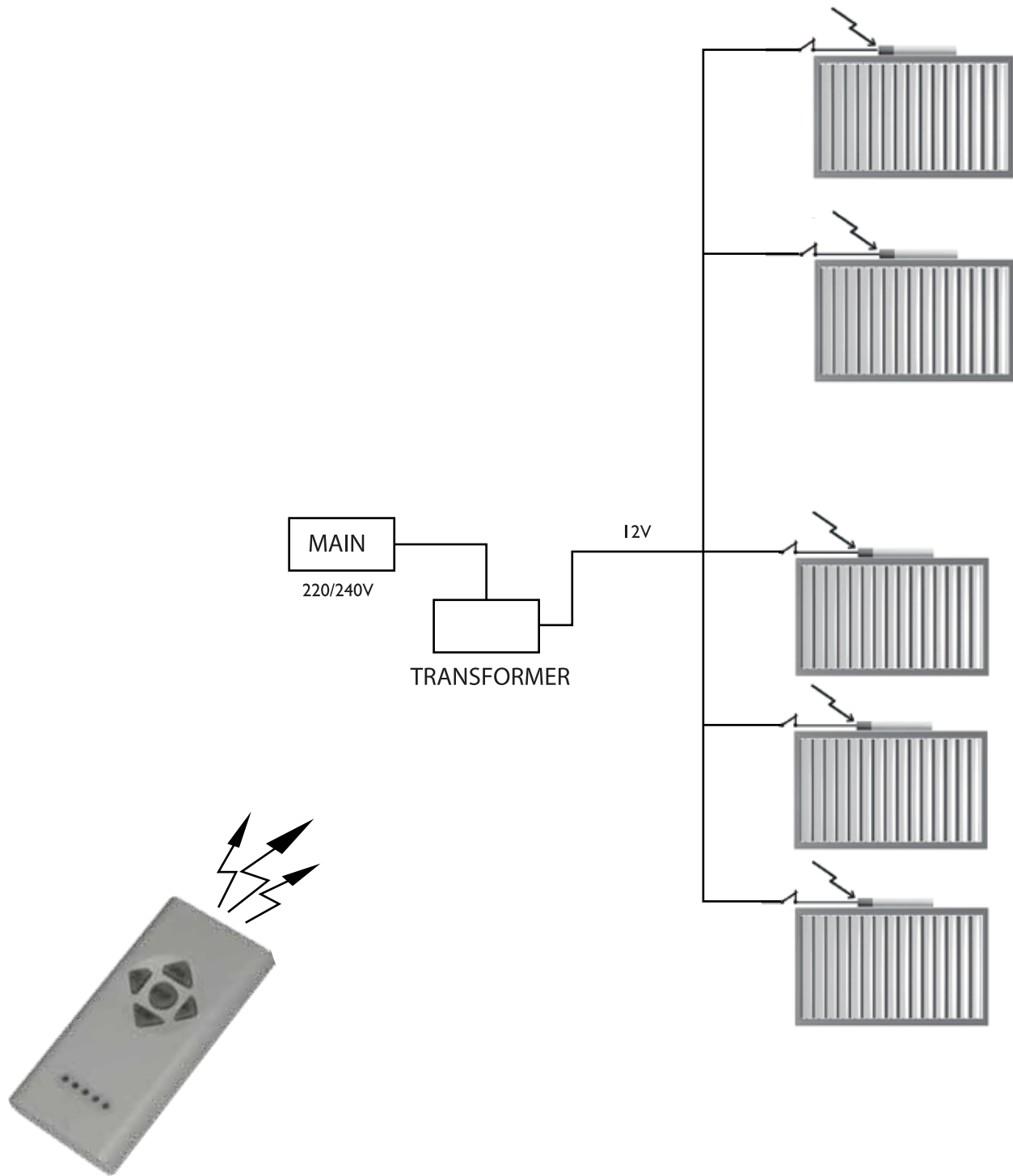

MAMAS STAVROU LTD
Aluminium Pergolas
Sun-breakers & Louvers
Τηλ.: 22 429151, 22 420069. Φαξ: 22 316609

www.mamastavrou.com



REMOTE CONTROL OPERATION - PARTS



1.5 A Tranformer



Receiver



2.5 A Tranformer



Switch



6.3 A Tranformer



Linear Actuator



5 CH Transmitter

