

# TECHNICAL DETAILS//MU 932

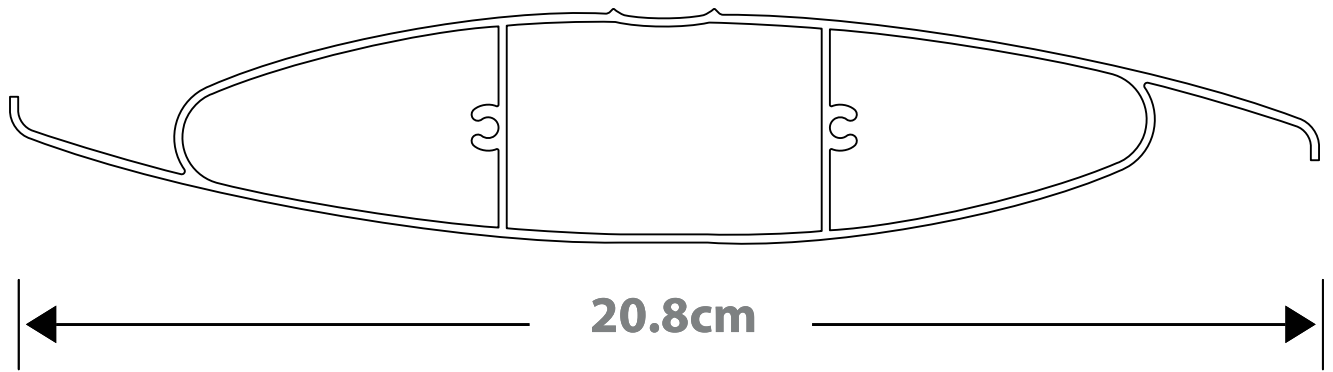

## BLADE SPECIFICATIONS

// Blade cover - opening system _____ 200 mm	// Weight per lineal metre _____ 1.747 kgm
// Weight per square metre - opening system _____ 8.735 kg/sqm	// Actual blade width _____ 207.8 mm
// Blade centres - opening system _____ 200 mm	

## INSTALLATION OPTIONS

### OPENING DIRECTION OF BLADES

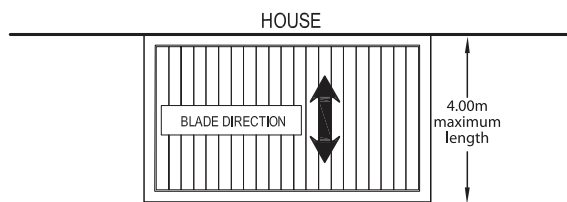

By placing the blades vertical to the wall, there are no limitations regarding the **width** of the structure

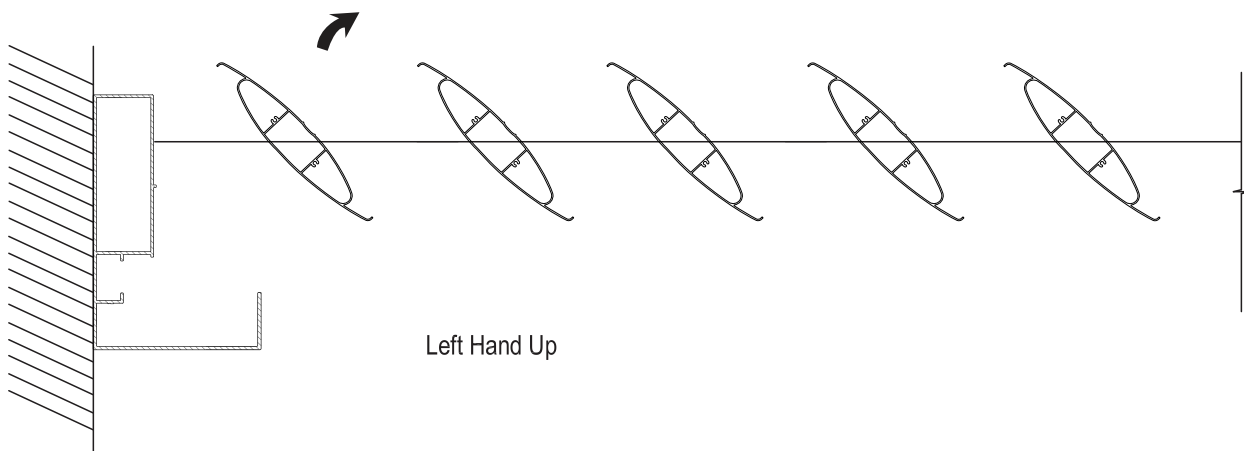

**MAMAS STAVROU LTD**  
**Aluminium Pergolas**  
**Sun-breakers & Louvers**  
Τηλ.: 22 429151, 22 420069. Φαξ: 22 316609

[www.mamastavrou.com](http://www.mamastavrou.com)



# TECHNICAL DETAILS// MU 932

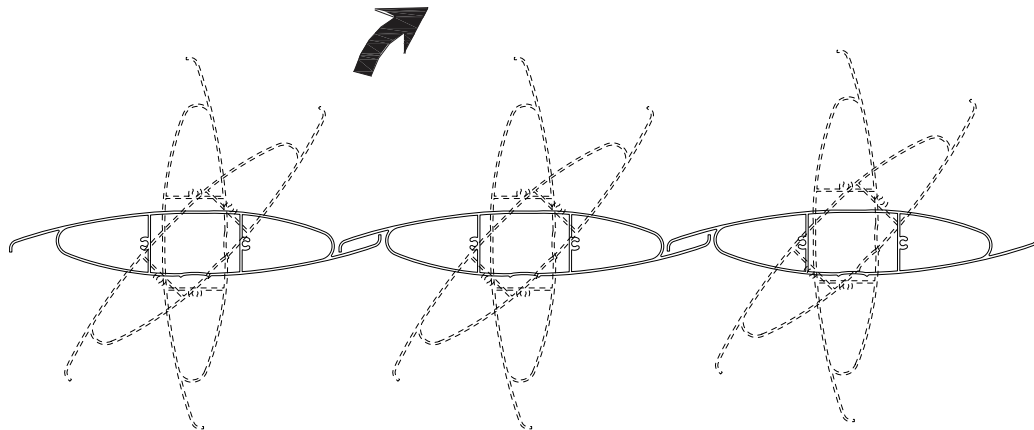
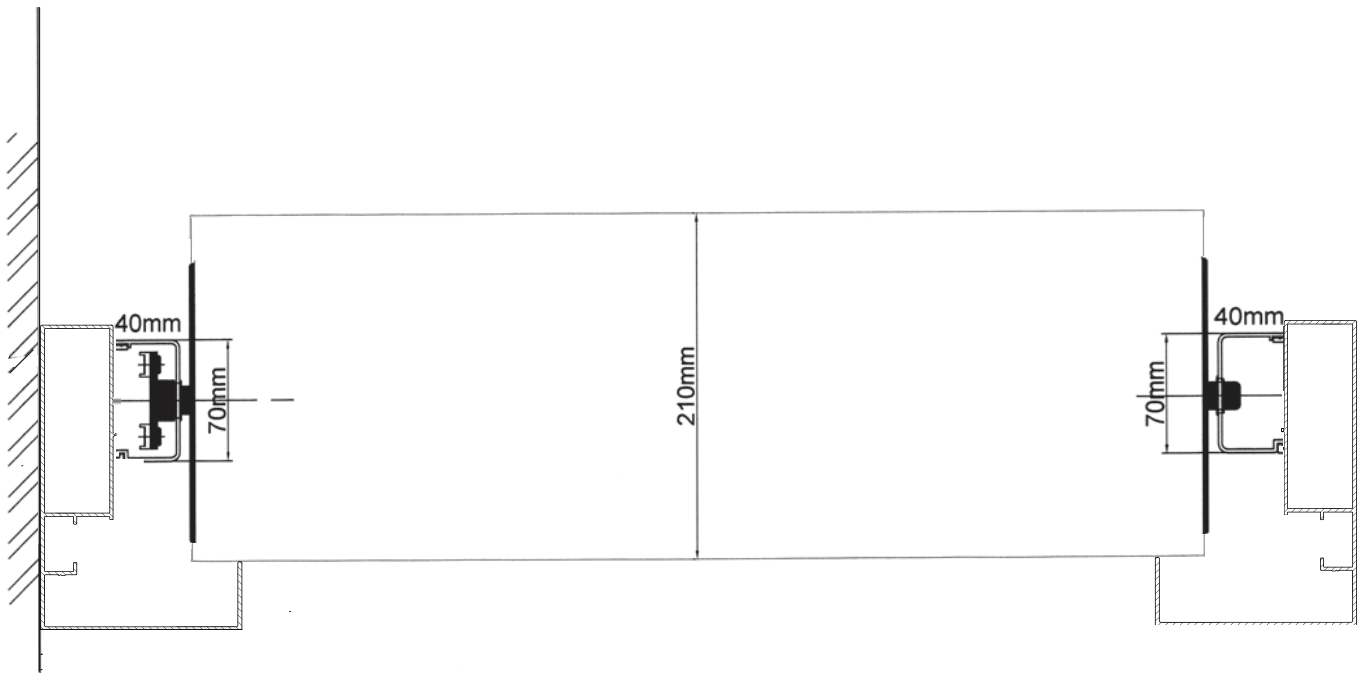

**MAMAS STAVROU LTD**  
**Aluminium Pergolas**  
**Sun-breakers & Louvers**  
Τηλ.: 22 429151, 22 420069. Φαξ; 22 316609

[www.mamastavrou.com](http://www.mamastavrou.com)



015

## Remote control operation

IMPORTANT PLEASE NOTE: We recommend that at an early stage involve your electrician. This applies for both new and existing buildings. Determine with us how to achieve the outcomes you would like against possible limitations caused by the building. Mamas Stavrou Ltd will provide a wiring diagram and installation instructions.

The remote control unit controls up to 5 linear actuators simultaneously or individually. Maximum construction size per linear actuator 20m<sup>2</sup>.

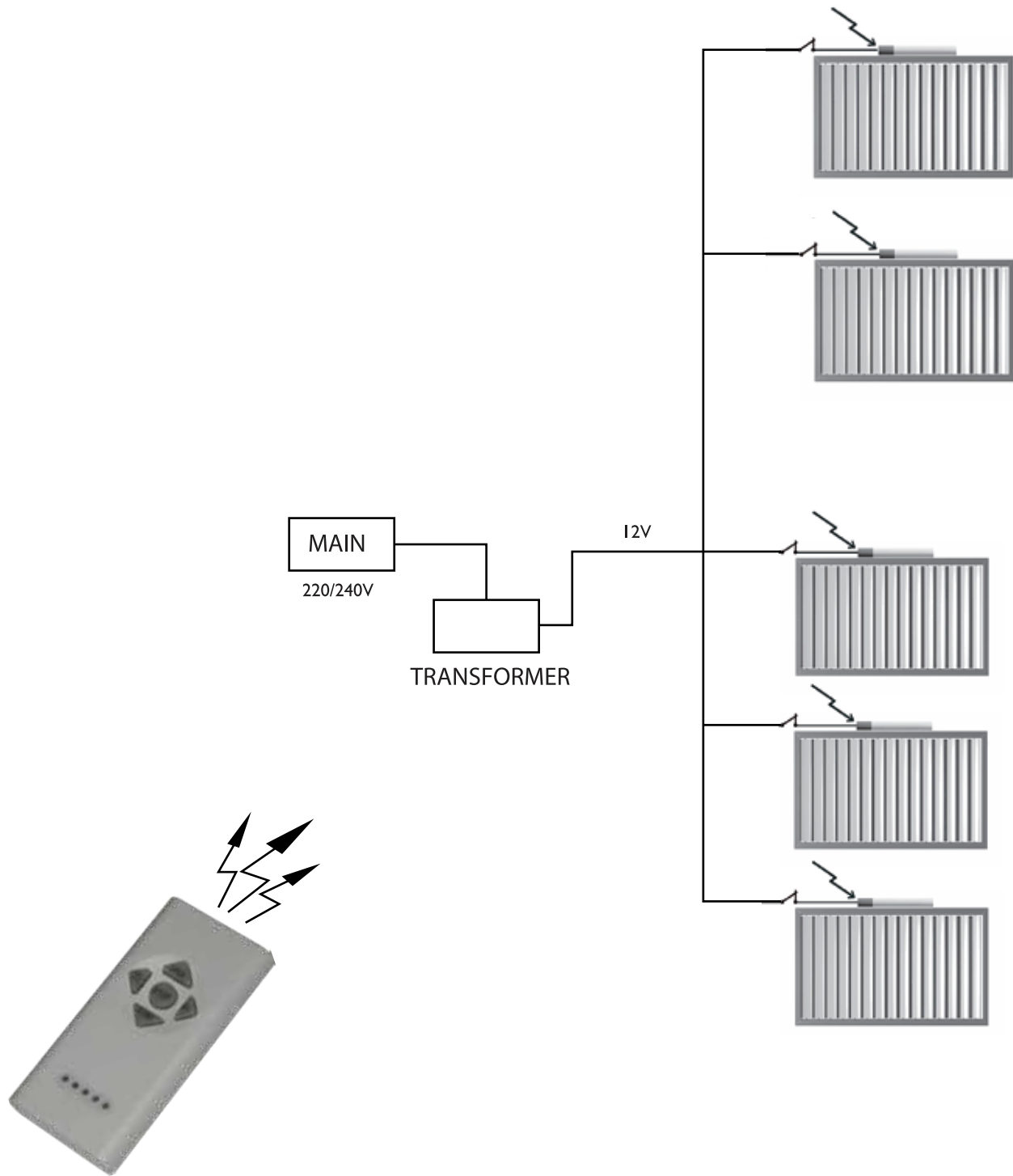

**MAMAS STAVROU LTD**  
**Aluminium Pergolas**  
**Sun-breakers & Louvers**  
Τηλ.: 22 429151, 22 420069. Φαξ: 22 316609

[www.mamastavrou.com](http://www.mamastavrou.com)



# REMOTE CONTROL OPERATION - PARTS



1.5 A Tranformer



Receiver



2.5 A Tranformer



Swich



6.3 A Tranformer



Linear Actuator



5 CH Transmitter

